

OIL & GAS VALVES

DUAL PILOT OPERATED CHECK VALVE | PRODUCT DETAIL

Description

This pressure operated valve assembly supports critical applications and is optimized for low leakage and high reliability in water based fluids. The discreet cartridges operate off a common pilot signal.

Features

- Bidirectional flow with pressure applied
- Dual check valves in series for redundancy
- NACE compliant corrosion resistant materials
- High cycle life with water-based fluids
- Manifold design customized to fit applications

Specifications

- Operating Pressure: 5,500 psig (380 Bar)
- External Pressure: 4,800 psi (330 Bar) max
- Voltage: 18-28 VDC
- Flow/Pressure Drop: 0.26 gpm (984 mL/min) at 2000 psid (138 Bar)
- Internal Leakage: 1 drop per minute
- Response Opening: 100 msec at max pressure/voltage
- Coil Resistance: 72-78 Ohms/min at +68°F (20°C)
- Operating Temperature: Above freezing point of media to +122°F (+50°C)

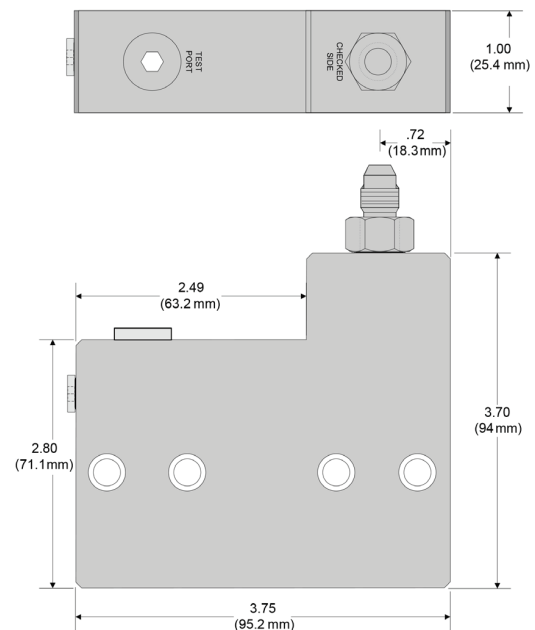
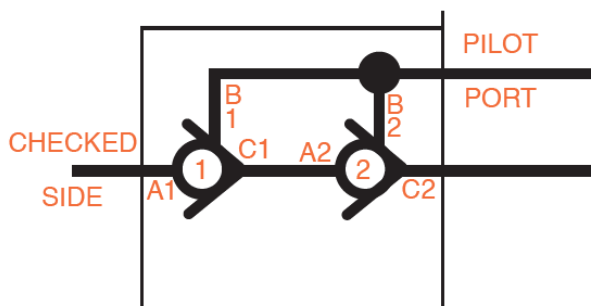

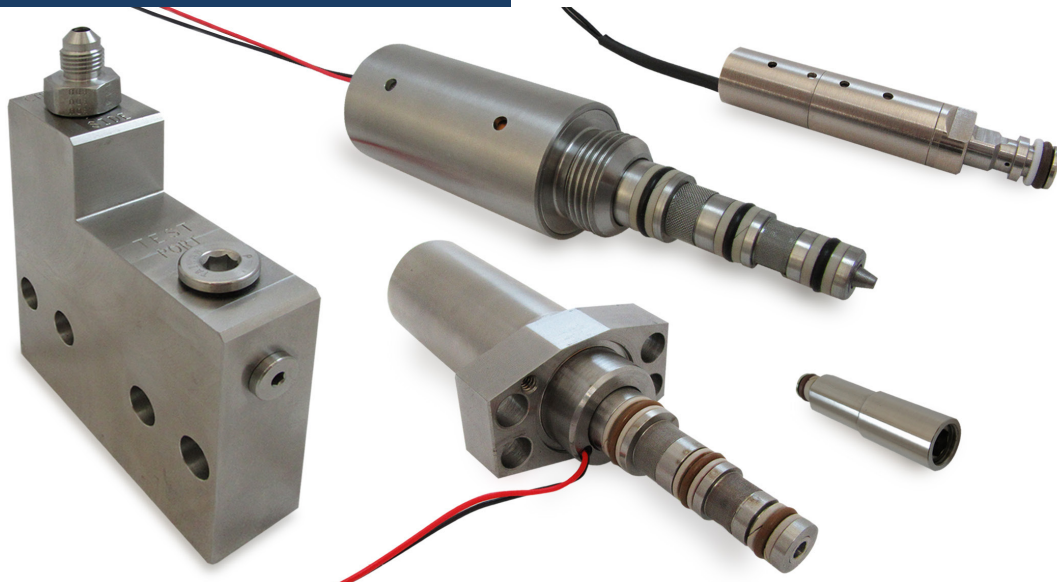

We specialize in customized valves for Topside Exploration & Production, Downhole Drilling & Completion, Subsea Production & Processing, and Chemical Processing. We utilize advanced 3D design, stress/CFD modeling, in-house testing and validation to provide world class products. LISK has been helping our customers reach new depths through collaborative engineering since 1910. Our family of oil and gas valves includes:

- Solenoid
- Direct Operated Control
- Pilot Operated Control
- Pilot Operated Relief
- Pressure Relief
- Shuttle
- Check Valves



ABOUT US

We are a global leader in the design and manufacture of engineered solutions including solenoids, solenoid valves, linear and rotary position sensors, motors, electric actuators and flame arrestors. We serve hundreds of customers in diverse markets throughout the world with market-leading solutions enabled by our extensive design, test and manufacturing capabilities.

